



by

JH INDUSTRIES, INC.

Edge-of-Dock

SEL Series

Copperloy offers both Mechanical and Hydraulic Edge-of-Dock Levelers available in 66", 72", 78" and 84" width's
20,000 lb. and 30,000 lb. capacities

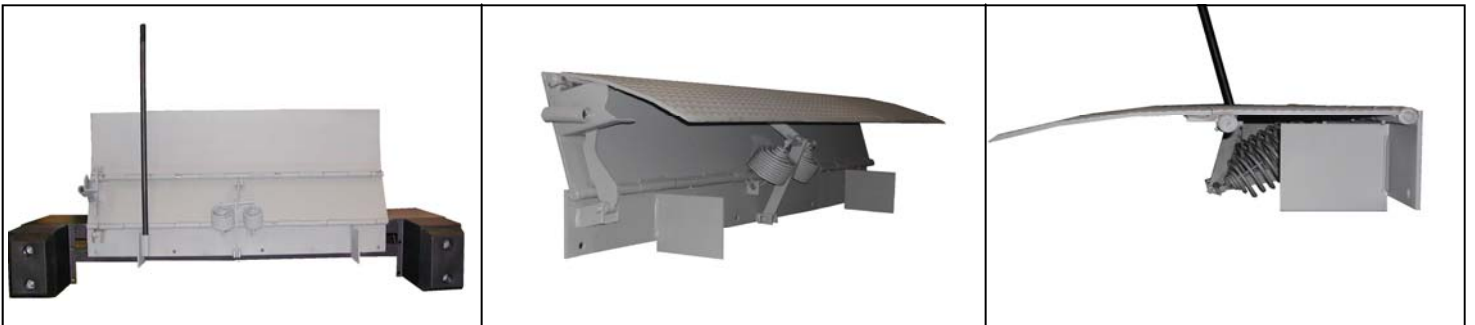

Simply pull back the handle and the lip will mechanically lift over the dock height. Then, a slight forward push of the handle will position the lip onto the truck floor.

FEATURES AND BENEFITS:

Our Edge-of-Dock Levelers are smooth and easy to operate. Whether using the handle or the wall-mounted push button (on the hydraulic unit) your Edge-of-Dock extends fully to the height of the trailer bed for safe freight handling. **All the benefits of the mechanical system are also available in our hydraulic models.**

To ensure product durability, the Copperloy Edge of Dock has been designed and engineered using a three dimensional engineering software package.

Quick, easy lifting and positioning:

Our exclusive lift mechanism and spring assembly sets the board in place with one-quarter the effort needed to operate a conventional edge of dock.

Push button operation on hydraulic models.

Ideal for retrofit: The Copperloy Edge of Dock easily mounts to the face of almost any dock. Transition plates and approach ramps are also available.

Safety: All Copperloy Edge of Dock Levelers are equipped with a **safety maintenance strut** to secure the unit while performing routine maintenance.

Low maintenance: Maintenance is reduced to simple lubrication of hinges which come equipped with grease fittings.

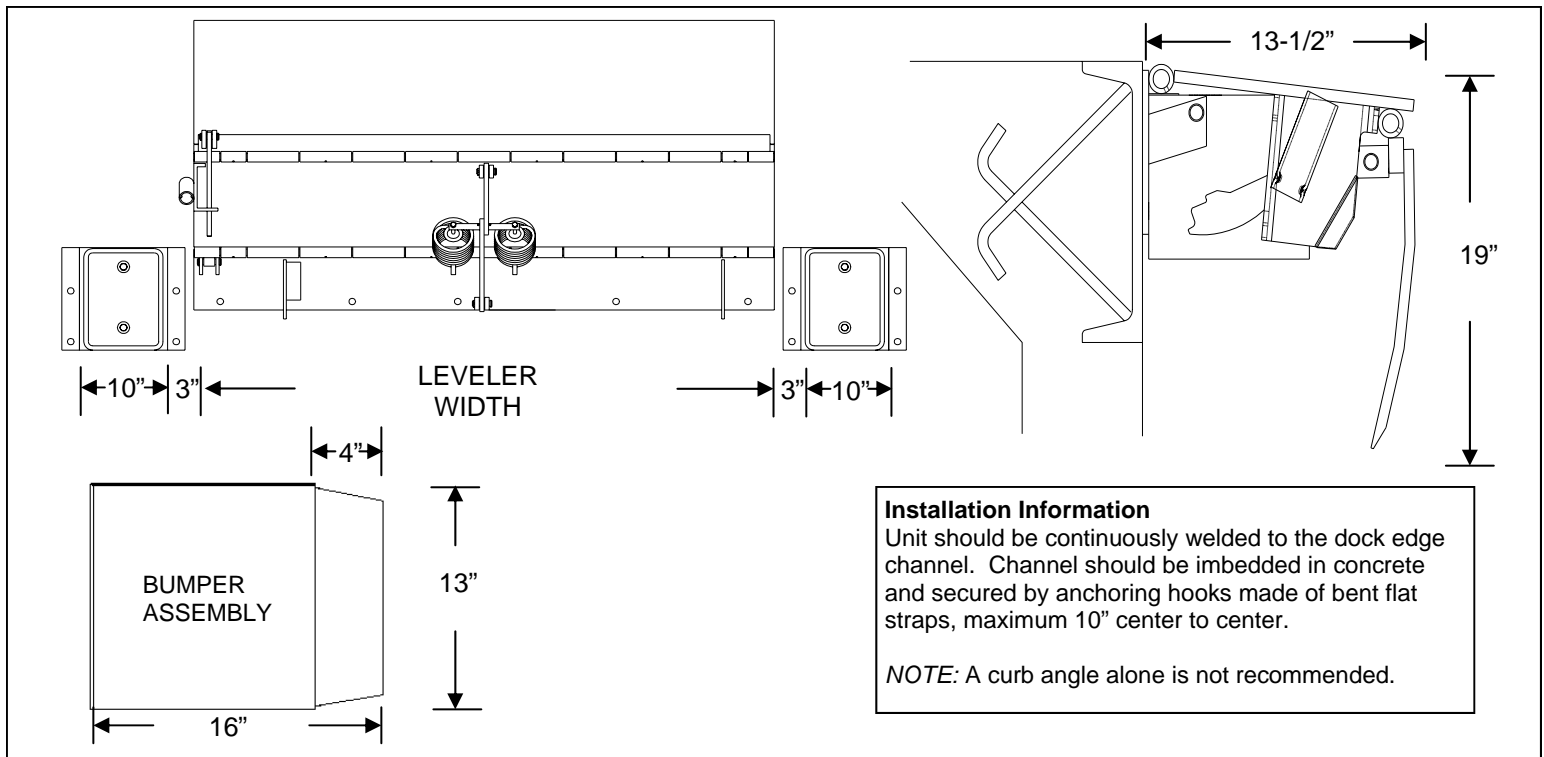

SPECIFICATIONS:

Materials: High strength low alloy (50,000 lb. Minimum Yield) tread plate, lip beveled for smooth transition.

Projections: Bumpers 16". Ramp 13 1/2" in stored position. Lip extends 12 1/2" beyond bumper.

Bumpers: 4" x 13" x 10" molded reinforced rubber mounted to steel box frame.
 • Optional 4" x 12" x 13" bumper assembly

Lift Assist: Dual extension springs.

Finish: Unit is completely cleaned, deburred and painted gray.

Service Range: Capable of servicing trucks 5" above and 5" below the dock.

Capacities: 20,000 lb. and 30,000 lb.

Widths: 66", 72", 78", 84"

Options: (Consult factory for more information)

- Refer lip
- Reduced lip bend
- In-Board Handle Assembly
- Hydraulic Model— 115/230 VAC Single Phase

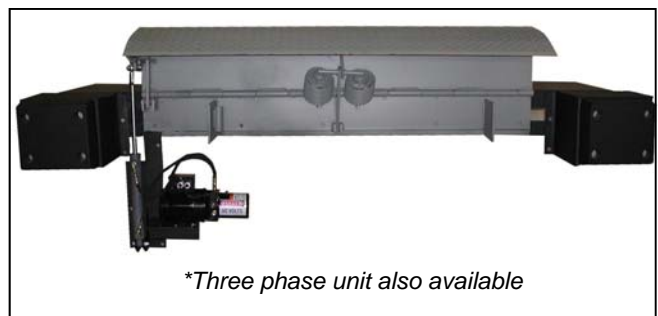

CAM Model (12.5" Projection)

<u>Capacity</u>	66" wide	72" wide	78" wide	84" wide
20,000 Lb.	SEL2066CG	SEL2072CG		
30,000 Lb.	SEL3066CG	SEL3072CG	SEL3078CG	SEL3084CG

Refer Model (14" Projection)

<u>Capacity</u>	66" wide	72" wide	78" wide	84" wide
20,000 Lb.	SEL2066CRG	SEL2072CRG		
30,000 Lb.	SEL3066CRG	SEL3072CRG	SEL3078CRG	SEL3084CRG